

INSTRUCTION SHEET

MARVEL-SCHEBLER CARBURETOR MODEL-TSX

GENERAL EXPLODED VIEW

THE GENERAL DESIGN AND PARTS SHOWN WILL VARY TO INDIVIDUAL UNITS COVERED ON THIS INSTRUCTION SHEET

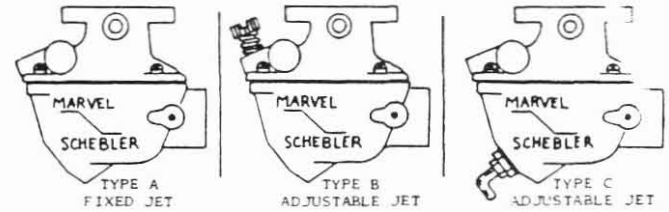
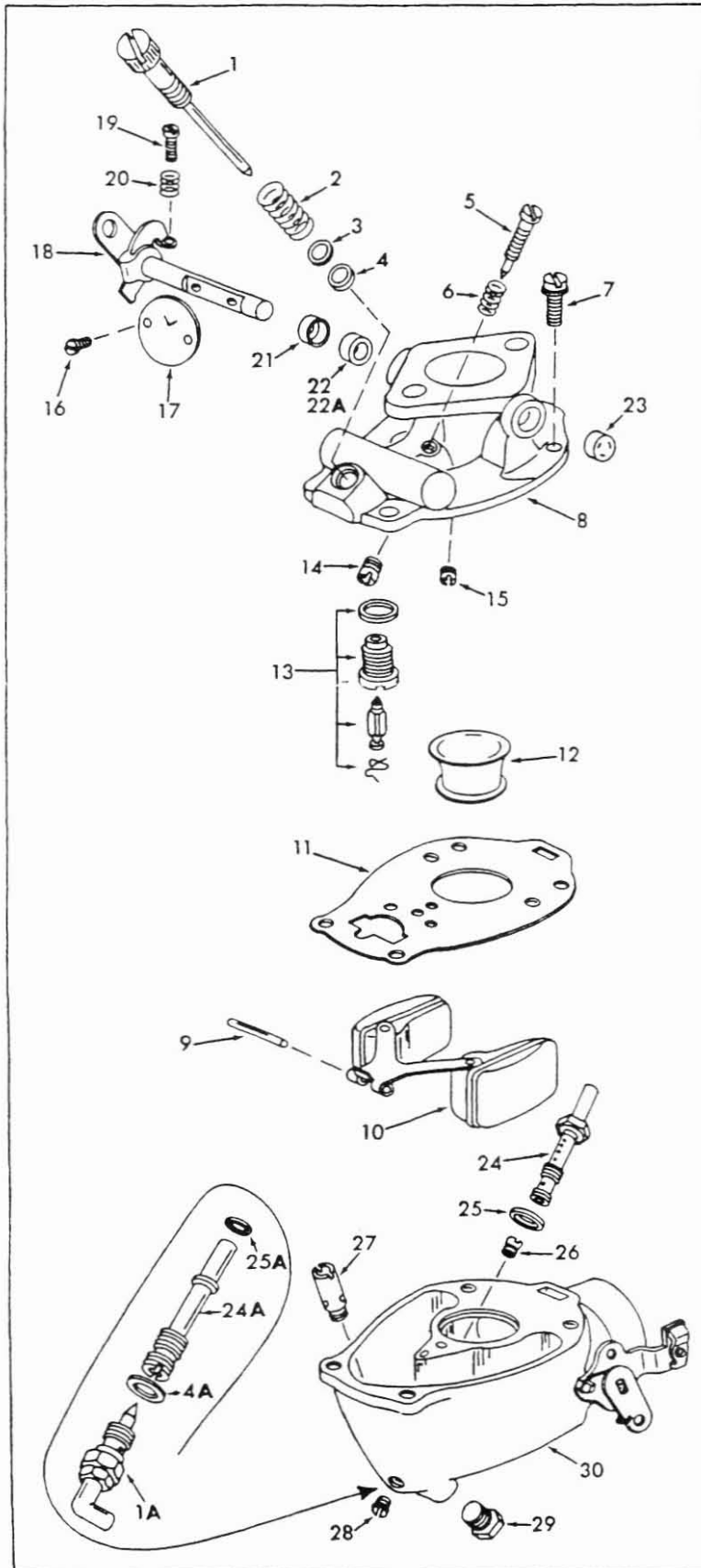

DISASSEMBLY

USE EXPLODED VIEW AS A GUIDE. THE NUMERICAL SEQUENCE MAY GENERALLY BE FOLLOWED TO DISASSEMBLE UNIT FAR ENOUGH TO PERMIT CLEANING AND INSPECTION. NOTE: IDLE JET (14) AND ECONOMIZER JET (15) ARE NOT USED IN ALL CARBURETORS. WHEN REMOVING IDLE JET (14), ECONOMIZER JET (15), OR POWER JET (26) BE SURE TO USE THE PROPER SIZE SCREW DRIVER. JETS CAN EASILY BE BROKEN. BEFORE REMOVING THROTTLE VALVE (17), NOTE ANGLE IDENTIFICATION MARK FACING FLANGE FACE OF CARBURETOR. POWER ADJUSTING NEEDLE SEAT (27) NOT USED IN ALL TYPE B CARBURETORS.

NOMENCLATURE

REF. NO.	REF. NO.
1. NEEDLE-POWER ADJ. (TYPE B)	15. JET-ECONOMIZER
1A. NEEDLE ASSY.-POWER ADJUSTING (TYPE C)	16. SCREW & LOCKWASHER (2) - THROTTLE VALVE
2. SPRING-POWER ADJ. NEEDLE	17. THROTTLE VALVE
3. WASHER-FLAT POWER ADJ. NEEDLE SPRING	18. SHAFT & LEVER ASSY.-THROTTLE
4. GASKET-POWER ADJ. NEEDLE	19. SCREW-THROTTLE STOP
4A. GASKET-POWER ADJ. NEEDLE ASSY. (TYPE C)	20. SPRING-THROTTLE STOP SCREW
5. NEEDLE-IDLE ADJUSTING	21. RETAINER-THROTTLE SHAFT SEAL
6. SPRING-IDLE ADJ. NEEDLE	22. SEAL (FELT)-THROTTLE SHAFT
7. SCREW & LOCKWASHER (4) - BOWL COVER	22A. SEAL (RUBBER)-THROTTLE SHAFT
8. BOWL COVER	23. CUP-THROTTLE SHAFT
9. PIN-FLOAT LEVER	24. NOZZLE-MAIN (TYPE A-B)
10. FLOAT & LEVER ASSY.	24A. NOZZLE-MAIN (TYPE C)
11. GASKET-BOWL COVER	25. GASKET-MAIN NOZZLE (TYPE A-B)
12. VENTURI	25A. GASKET-MAIN NOZZLE (TYPE C)
13. NEEDLE, SEAT & GASKET ASSY.	26. JET-POWER (TYPE A-B)
14. JET-IDLE	27. SEAT-POWER ADJ. VDL. (TYPE B)
	28. SCREW-PLUG
	29. PLUG-BOWL DRAIN
	30. BOWL ASSY.-FLOAT

CLEANING

CLEANING MUST BE DONE WITH CARBURETOR DISASSEMBLED. SOAK PARTS LONG ENOUGH TO SOFTEN AND REMOVE ALL FOREIGN MATERIAL. USE (1) A CARBURETOR CLEANING SOLVENT, (2) LACQUER THINNER, OR (3) DENATURED ALCOHOL. MAKE CERTAIN THE THROTTLE BORES ARE FREE OF ALL CARBON AND VARNISH DEPOSITS. RINSE OFF IN SUITABLE SOLVENT. BLOW OUT ALL PASSAGES IN CASTINGS WITH COMPRESSED AIR AND CHECK CAREFULLY TO INSURE THOROUGH CLEANING OF OBSCURE AREAS. CAUTION: DO NOT SOAK RUBBER PARTS OR POWER ADJUSTING ASSEMBLY (1A) TYPE C IN CLEANING SOLVENT.

REASSEMBLY

REASSEMBLE IN REVERSE ORDER OF DISASSEMBLY. NOTE SPECIAL INSTRUCTIONS.

SPECIAL INSTRUCTIONS

THROTTLE SHAFT SEAL AND RETAINER INSTALLATION - ASSEMBLE RETAINER (21) AND FELT SEAL (22), OR RUBBER SEAL (22A) WITH RETAINER IF REQUIRED, ON THROTTLE SHAFT. INSERT SHAFT IN CARBURETOR AND TAP LIGHTLY UNTIL RETAINER IS FLUSH WITH CASTING.

THROTTLE VALVE (17) INSTALLATION - INSTALL VALVE WITH ANGLE IDENTIFICATION MARK FACING FLANGE FACE OF CARBURETOR. TAP LIGHTLY TO CENTER IN THROTTLE BORE, TIGHTEN SCREWS SECURELY.

IDLE ADJUSTING NEEDLE (5) - TURN NEEDLE IN LIGHTLY UNTIL SEATED, THEN BACK OUT 1 TURN.

POWER ADJUSTING NEEDLE (1) OR (1A) - TURN NEEDLE IN LIGHTLY UNTIL SEATED, THEN BACK OUT 1 TURN.

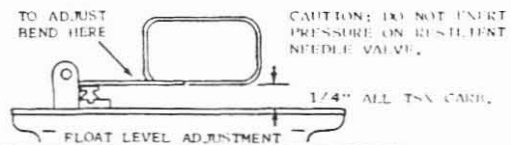

MEASURE FROM GASKET SURFACE TO NEAREST EDGE OF EACH FLOAT. TO ADJUST, BEND FLOAT LEVER KEEPING EDGE OF FLOAT PARALLEL WITH GASKET.

IDLE ADJUSTMENT - ENGINE AT OPERATING TEMPERATURE, CHOKER VALVE COMPLETELY OPEN, ADJUST IDLE SCREW UNTIL ENGINE RUNS SMOOTHLY STAYING ON THE RICH SIDE OF THE ADJUSTMENT.

POWER ADJUSTMENT - ENGINE RUNNING AT GOVERNED SPEED UNDER LOAD, TURN POWER ADJUSTING NEEDLE CLOCKWISE UNTIL ENGINE BEGINS TO LOSE POWER, THEN BACK OUT UNTIL ENGINE PICKS UP POWER AND RUNS SMOOTHLY. A RICHER MIXTURE WILL BE NEEDED TO IMPROVE ACCELERATION.

SERVICE INSTRUCTIONS FOR CARBURETORS EQUIPPED WITH ANTI-DIESELING POWER ADJUSTING NEEDLE

REMOVE UNIT FROM CARBURETOR. DISASSEMBLE AS SHOWN. DO NOT TRY TO REMOVE O-RING. WASH IN CLEANING SOLVENT AND BLOW OFF WITH COMPRESSED AIR. CAUTION: DO NOT SOAK COIL ASSEMBLY OR RUBBER O-RING IN CARBURETOR CLEANER.

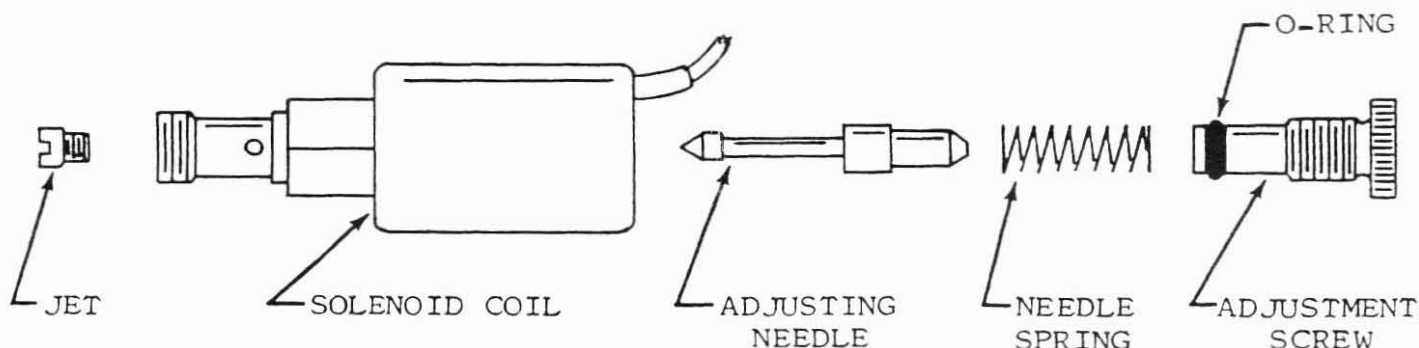

ASSEMBLY: LIGHTLY OIL O-RING AND REASSEMBLE IN REVERSE ORDER OF DISASSEMBLY.

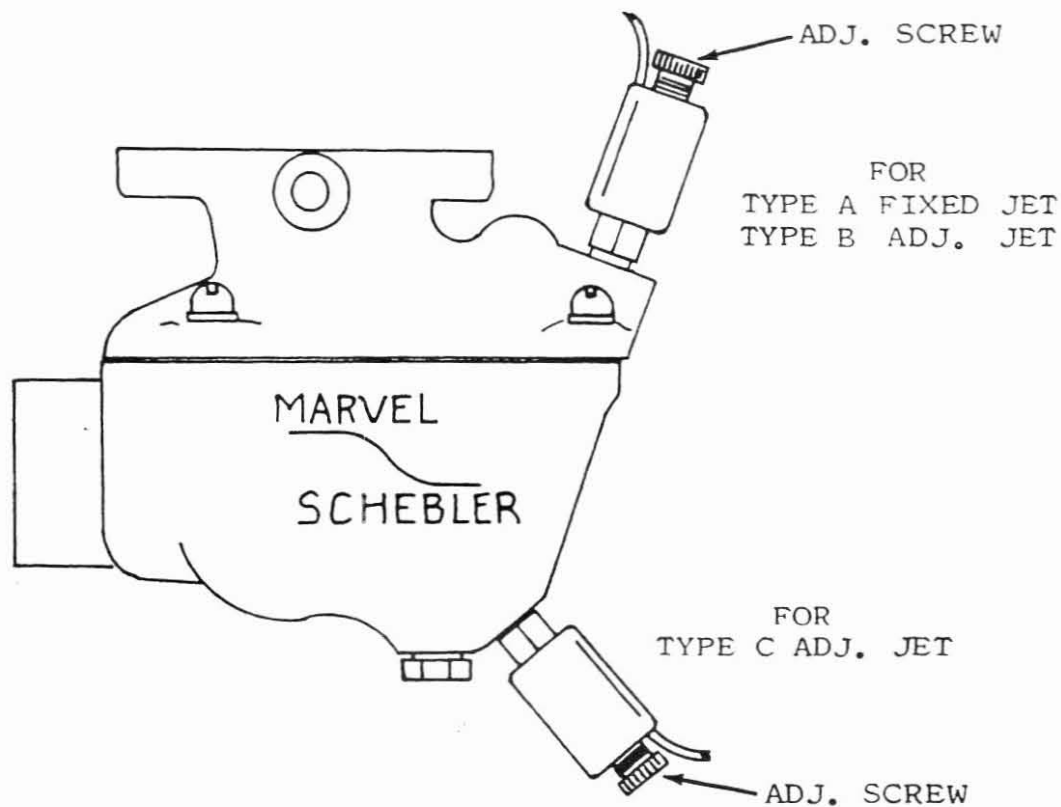

PRELIMINARY SETTING. TURN ADJUSTMENT SCREW IN LIGHTLY UNTIL NEEDLE SEATS, THEN BACK OUT 2-3 TURNS. FINAL SETTING UNDER LOAD IN ACCORDANCE WITH YOUR ENGINE MANUAL.