

INSTRUCTION SHEET

ROCHESTER CARBURETOR—MODELS—"H",—"HV".

I. DISASSEMBLY.

Using the exploded view on the reverse side of this sheet as a guide, disassemble the carburetor far enough to permit thorough cleaning and inspection of parts. After removal of the air-horn assembly (23), the pump return spring (24) and pump discharge needle (25) will be loose in the body and bowl assembly (33). These parts will fall out when the body (33) is tilted up-side-down. This also applies to the main well insert (31) after removal of the venturi cluster assembly (29). Exercise care not to lose these parts during disassembly.

II. CLEANING.

Soak parts long enough to soften and remove all foreign material. Use a regular carburetor cleaning solvent, lacquer thinner or denatured alcohol. Use a small brush to aid cleaning if necessary. Make certain the body and bowl assembly (33) is free of all carbon deposits around the throttle valves and blow out all passages in the casting with compressed air. Rinse parts thoroughly in clean solvent after all foreign material has been loosened.

III. REASSEMBLY.

Reassemble the carburetor using essentially the reverse order of disassembly. Give particular attention to the following:

a. When attaching the pump plunger assembly (19) to the operating lever (which was not removed from the air horn assembly 23) make sure the end of pump plunger (19) points toward the outside edge of the air-horn to insure proper alignment in the pump cylinder.

b. When installing the pump discharge needle (25), make sure the tapered end of the needle is pointing downward.

c. When installing the pump rod (10), position it as shown in the exploded drawing. Pump operation will be affected if this is reversed.

d. When installing the idle-adjusting needle (11) rotate it lightly against its seat then back it out one full turn for a trial adjustment.

IV. ADJUSTMENTS.

a. **Float Level Adjustment.** (See figure 1.) With air horn assembly up-side-down and air horn gasket in place, use float gage supplied to gage float level. Place the float gage over the float pontoons, nearest the float hinge. Move the gage outward away from the hinge point. The bottom surfaces of the float pontoons must just touch float gage at front and rear surfaces and must be parallel with air horn casting. Bend the float pontoons at the solder connection on the float lever to make them parallel and bend the tang on float lever to adjust float level.

b. **Float Drop Adjustment.** (See figure 2.) With air horn assembly right-side-up, and the float assembly hanging freely, measure the distance "A" to the gasket surface of the air horn as shown. See specification column for dimension. To adjust, bend stop tang on float lever.

c. **Pump Adjustment.** (See figure 3.) Back out throttle stop screw until the throttle valve is fully seated in carburetor bore, the index line on the pump lever should be aligned with the sharp edge of the air horn casting. To adjust, increase or decrease the bend near the center of the pump rod as required.

d. **Idle Adjustment.** (See figure 4.) The Corvair engine is equipped with two carburetors and to provide proper engine performance it is necessary to synchronize the two throttle valves before adjusting the idle mixture screws. Adjust the idle mixture screws and synchronize throttle stop screws to produce a smooth idle at 450-500 rpm for manual transmissions and 475-500 rpm (in drive) for automatic transmissions.

ADJUSTMENT DATA TABLE

Year & Make	Float Level	Float Drop	Pump Rod
1960-62 Corvair	1 7/32"	1 3/4"	Index
1963 Corvair	1 3/16"	1 3/4"	Index
1964-69 Corvair-All	1 1/16"	1 13/16"	Index
Aquanautics	1 1/16"	1 13/16"	Index
Inboard Marine	1 3/16"	1 3/4"	Index

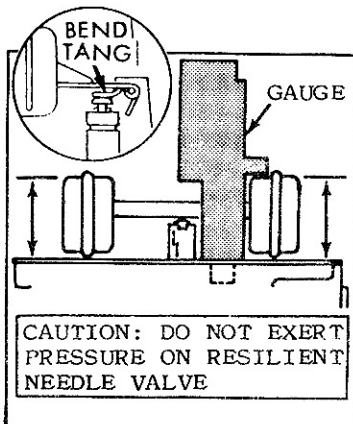

FLOAT LEVEL Fig.1

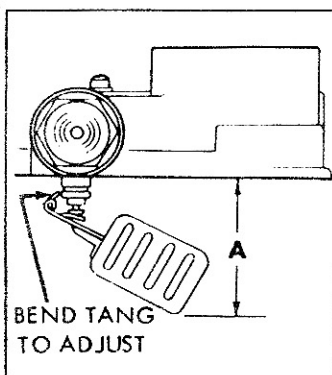

FLOAT DROP Fig.2

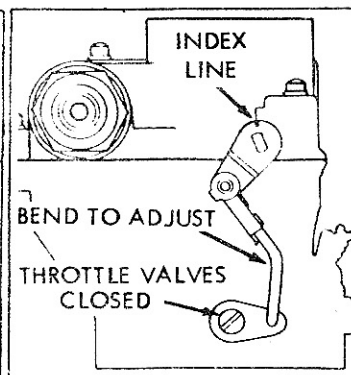

PUMP ADJ. Fig.3

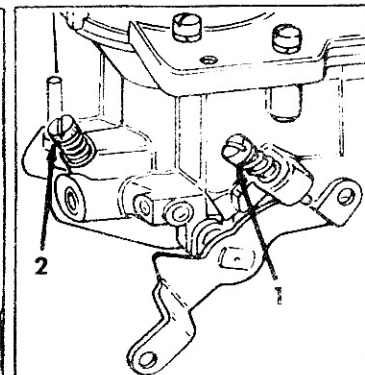

IDLE ADJ. Fig.4

GENERAL EXPLODED VIEW

THE GENERAL DESIGN AND PARTS SHOWN WILL VARY TO INDIVIDUAL UNITS COVERED ON THIS INSTRUCTION SHEET

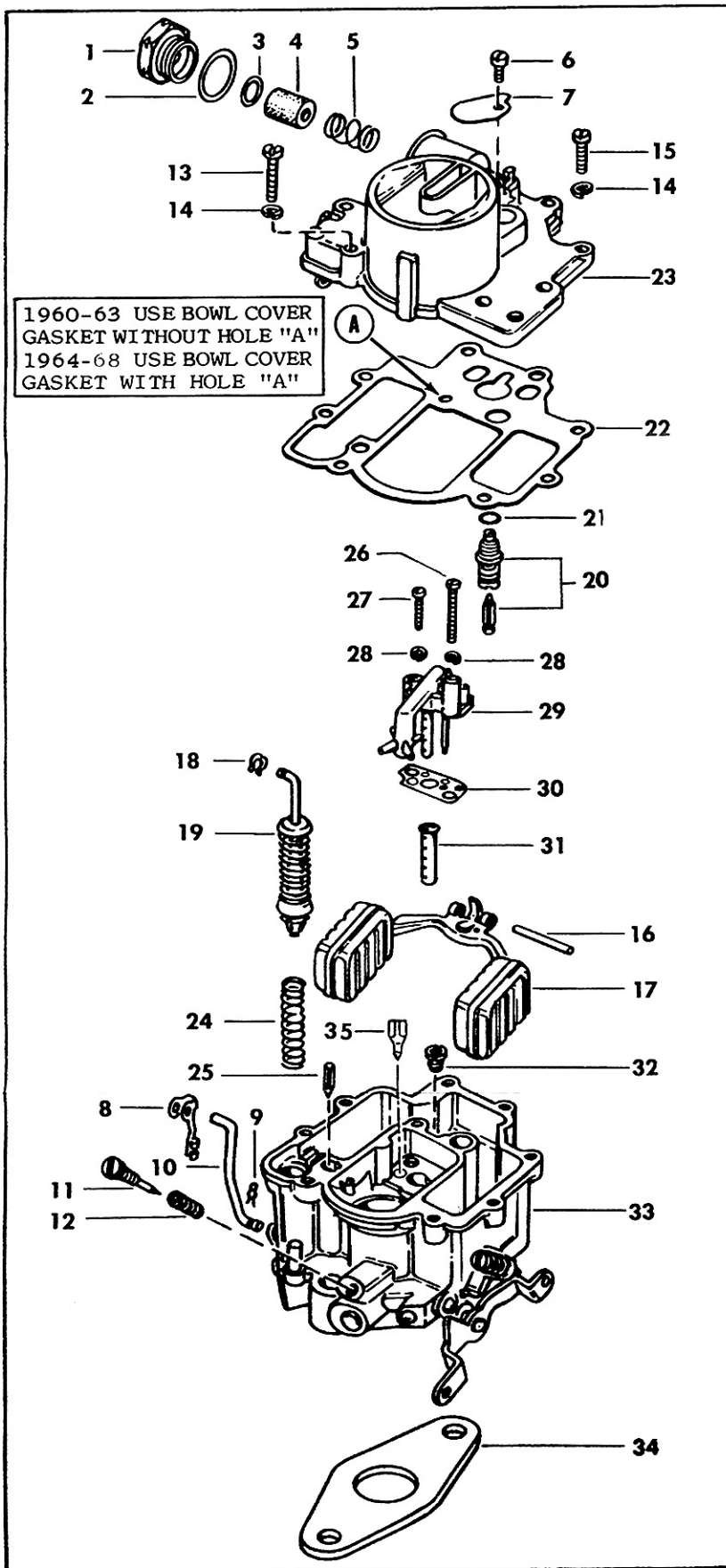

1960-63 USE BOWL COVER
GASKET WITHOUT HOLE "A"
1964-68 USE BOWL COVER
GASKET WITH HOLE "A"

Ref.
No.

NOMENCLATURE

1. Fuel inlet filter nut
2. Fuel inlet nut gasket
3. Fuel inlet filter gasket
4. Fuel inlet filter
5. Fuel inlet filter spring
6. Cover screw
7. Cover
8. Pump rod retainer
9. Pump rod retainer (hairpin)
10. Pump rod
11. Idle adjusting needle
12. Idle needle spring
13. Air horn screw (long)
14. Lock washer
15. Air horn screw (short)
16. Float hinge pin
17. Float assembly
18. Pump plunger clip
19. Pump plunger assembly
20. Needle and seat assembly
21. Needle seat gasket
22. Air horn gasket
23. Air horn assembly
24. Pump return spring
25. Pump discharge needle
26. Venturi cluster screw (long)
27. Venturi cluster screw (short)
28. Lock washer
29. Venturi cluster assembly
30. Venturi cluster gasket
31. Main well insert
32. Main-metering jet
33. Body and bowl assembly
34. Heat insulator
35. Power Enrichment Needle -
(All 1965 - 67 primary carburetors.)
(Not used in 4 x 1 secondary carbs.)